

Rabbit-S Specification

Project:Rabbit/Bluetooth 5 BLE module

Module name:Rabbit-S

Designed:Suzhou Pairlink Network Technology Ltd.

Version	Note	Date
V1.0	Create	2021/06/30
V1.1	Modify Packing Information	2022/03/15

This document contains information that is proprietary to Pairlink . This document is commercially confidential and must NOT be disclosed to third parties without prior consent. The information provided herein is believed to be reliable. But production testing may not include testing of all parameters. Pairlink reserves the right to change information at any time without notification.

Content

1.Functional Characteristics - 3 -
 1.1.Product Feature - 3 -
 1.2. Main Application Domain - 3 -
2.Electrical Specifications - 4 -
 2.1.Absolute Ratings - 4 -
 2.2.Recommended Operating Conditions - 4 -
 2.3.Physical Parameters - 5 -
3.Peripheral Interface - 5 -
4.Hardware Design and PCB layout - 6 -
 4.1.Pin assignment and Pin description - 6 -
 4.2.Reference Design - 8 -
 4.3.Appearance and Dimensions - 9 -
 4.4.Module Layout Guideline - 10 -
5.Packing Information - 11 -
 5.1.Rolling Information - 11 -
6.Welding Declaration - 12 -

Suzhou Pairlink Network Technology Ltd.

1. Functional Characteristics

Rabbit-S is SOC module developed based on the Bluetooth 5.0 standards. the internal integration architecture ARM® Cortex®-M4 processor. It has the advantage of small volume, low power consumption, long distance transmission, strong anti-jamming capability, low cost. Specifically applied to Bluetooth low power control area, and suitable for various occasions short distance wireless communication.

Rabbit-S integral compact, integrated with a Ipex connector and the 25PIN surface patch package for easy the design in hardware and institution for user. The module interface open completely to make the users has more flexible secondary development space.

1.1. Product Feature

- 1: Support Pairlink transmission and control protocol, suitable for all kinds of smart devices. Pairlink also provides the design and development of APK / APP control software products. Provide a one-stop solution.
- 2: Industrial grade standard design, support long-term use at -40 ~ 85 °C.
- 3: Rabbit-S under Bluetooth 5 specification.
- 4: Ultra-low sleep power consumption. Supports GPIO wake-up and timer wake-up.
- 5: High receiving sensitivity.
-97 dBm sensitivity in Bluetooth®low energy mode.

1.2. Main Application Domain

- 1: MCU data pass-through.
- 2: Bluetooth Printer / Scanner / Digital price tag etc.
- 3: Remote control / Keyboard and Mouse / Toys / Smart phone self timer etc.
- 4: Industrial remote control / Industrial telemetry / Industrial data collection.
- 5: Smart home / Intelligent lighting / Intelligent access control system.

2. Electrical Specifications

2.1. Absolute Ratings

Parameter	Specification		Unit
	Min.	Max.	
Power Supply(V)	-0.3V	+3.6V	Burn the module permanently if it exceeds +3.6V
Storage temperature(°C)	-55	+125	
Working temperature (°C)	-40	+85	
ESD HBM	-3.5KV	+3.5KV	Human Body Model
ESD CDM	-500V	+500V	Charged Device Model

2.2. Recommended Operating Conditions

Parameter	Specification			Note
	Min.	Typical	Max.	
Power Supply(V)	1.8	3.3	3.6	
Communication level(V)		3.3		Can't communicate with 5V TTL level directly
Working temperature(°C)	-40	20	+85	
Consume	TX Current (mA)		10.2	TX Power=+4dBm
			12.7	TX Power=+8dBm
	RX Current (mA)		6.8	VBAT=3V3,1Mbps
	Sleep Current (uA)		3.8	Deep-sleep ,Supports GPIO wake-up and timer wake-up
TX Power(dBm)			+8	
Receive Sensitivity(dBm)			-97	1Mbps

Digital I/O Characteristic

Characteristics	Condition	Symbol	Specification			Unit
			Min.	Typical	Max.	
Input Low Voltage	VBAT=3V3	VIL	-	0	0.9	V
Input High Voltage		VIH	2.0	3.3	3.6	V
Output Low Voltage		VOL	0	-	0.33	V
Output High Voltage		VOH	2.97	-	3.3	V

2.3.Physical Parameters

Parameter	Performance	Note
Communication Distance	50M	Data Transfer (BLE) Environment: Sunny and open Airspeed: 1Mbps
Crystal	40MHz	Industry Standard
Protocol	BLE 5	Supported data rates: 1Mbps,2Mbps
Package	Patch	Refer to section 4.3
IC	RTL8762CMF	Packaging:QFN-40
Core	ARM Cortex-M4	
RAM	160KByte	
Flash	4Mbits	Embedded SOC memory
Dimensions	17.8mm*12.0mm*1.9mm	L*W*H
RF Interface	PCB Antenna	

3.Peripheral Interface

- 15 x Supermux GPIOs
- 2 x UART interface
- 2 x SPI interface with master configurable
- 2 x I2C interface with master/slave configurable
- 3 x 12-bit ADC input
- 8 x PWM interface
- 8 x General purpose Timer
- HW KeyScan

4. Hardware Design and PCB layout

4.1. Pin assignment and Pin description

Rabbit-S Pin definition can refer to Figure 1.

Table 1: Module Pin Description

<i>Pin Number</i>	<i>Pin Name</i>	<i>I/O</i>	<i>Alternate Function Description</i>
10	VBAT	P	Power Supply(DC1.8V~3.6V).
1,2,16,22,25	GND	P	Connect to Ground.
11	RESET	DI	Reset signal (active low).
13	LOG_OUT	DIO	Log_out,not intended for customer use.
18	P3_1	DIO	GPIO/UART_RX
19	P3_0	DIO	GPIO/UART_TX
23	32K_XI	A	
24	32K_XO	A	
3	P0_4	DIO	
4	P0_2	DIO	
5	P0_1	DIO	
6	P4_0	DIO	INPUT/OUTPUT with selectable pull up/down resistor.
7	P4_1	DIO	General purpose I/O port bit or alternate function nodes. Contain state retention mechanism during power down.
8	P4_2	DIO	
9	P4_3	DIO	
12	P5_0	DIO	
14	P1_0	DIO	
15	P1_1	DIO	
17	P2_3	DIO/AIN	GPIO/ADCIN3
20	P2_4	DIO/AIN	GPIO/ADCIN4
21	P2_5	DIO/AIN	GPIO/ADCIN5

Note: GPIO has integrated pull-up and pull-down resistors.

Support GPIO super multiplexing function, WAKE_UP / UART / SPI / IIC / PWM / and other functions can be arbitrarily configured on GPIO.

For more GPIO function configuration questions, contact to Pairlink.

As shown in the following table: GPIO Pin detailed Information.

Rabbit-B Rabbit-C Rabbit-S	GPIO Index	ADC	Hardware Default Pull setting(100K) Reset state	Rom Code Setting	Pull resistor	Bootcode Default	Wakeup Function	Drv ier current
P0_0	GPIO_0		Pull Down	Pull Down	10K/100K		Yes	8mA
P0_1	GPIO_1		Pull Down	Pull Down	10K/100K		Yes	8mA
P0_2	GPIO_2		Pull Down	Pull Down	10K/100K		Yes	8mA
P0_3	GPIO_3		Pull Up	Output High	10K/100K	LOG_UART_TX	Yes	8mA
P0_4	GPIO_4		Pull Down	Pull Down	10K/100K		Yes	8mA
P0_5	GPIO_5		Pull Down	Pull Down	10K/100K		Yes	8mA
P0_6	GPIO_6		Pull Down	Pull Down	10K/100K		Yes	8mA
P1_0	GPIO_8		Pull Up	Pull Up	10K/100K	SWDIO	Yes	8mA
P1_1	GPIO_9		Pull Up	Pull Up	10K/100K	SWDCLK	Yes	8mA
P5_0	GPIO_25		Pull Down	Pull Down	5K/50K		Yes	8mA
32k_XI	GPIO_26		Pull Down	Pull Down	10K/100K		Yes	8mA
32k_XO	GPIO_27		Pull Down	Output Low	10K/100K		Yes	8mA
P2_2	GPIO_18	ADC/LPC(channel 2) Differetial1+	Pull Down	Pull Down	5K/50K		Yes	8mA
P2_3	GPIO_19	ADC/LPC(channel 3) Differetial1-	Pull Down	Pull Down	5K/50K		Yes	8mA
P2_4	GPIO_20	ADC/LPC(channel 4) Differetial2+	Pull Down	Pull Down	5K/50K		Yes	8mA
P2_5	GPIO_21	ADC/LPC(channel 5) Differetial2-	Pull Down	Pull Down	5K/50K		Yes	8mA
P2_6	GPIO_22	ADC(channel 6) Differetial3+	Pull Down	Pull Down	5K/50K		Yes	8mA
P2_7	GPIO_23	ADC(channel 7) Differetial3-	Pull Down	Pull Down	5K/50K		Yes	8mA
P3_0	GPIO_24		Pull Up	Pull Up	10K/100K	UART_TX	Yes	8mA
P3_1	GPIO_25		Pull Up	Pull Up	10K/100K	UART_RX	Yes	8mA
P3_2	GPIO_26		Pull Down	Pull Down	10K/100K		Yes	8mA
P3_3	GPIO_27		Pull Down	Pull Down	10K/100K		Yes	8mA
P4_0	GPIO_28		Pull Down	Pull Down	10K/100K		Yes	8mA
P4_1	GPIO_29		Pull Down	Pull Down	10K/100K		Yes	8mA
P4_2	GPIO_30		Pull Down	Pull Down	10K/100K		Yes	8mA
P4_3	GPIO_31		Pull Up	Pull Up	10K/100K		Yes	8mA

4.2.Reference Design

The latest schematic and design examples, bill of material, and layout file are available from original developer . Contact us for details.

Figure 1: Module Reference Design

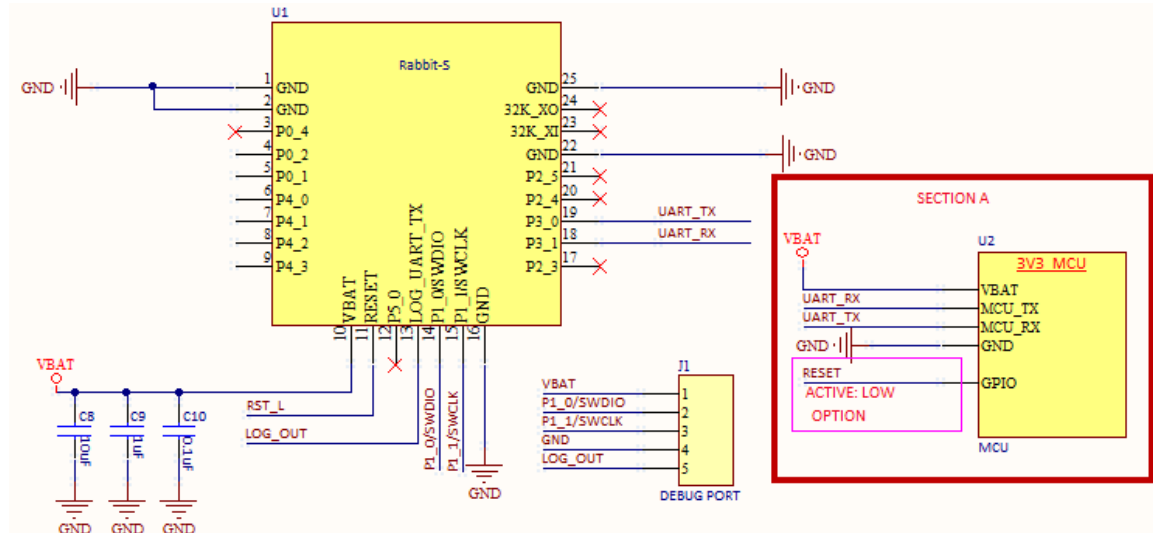

Circuit Description

1. VBAT supply voltage value is 1.80V-3.60V.
2. Every GPIOs can be used as a wake-up pin, and can be configured as a high-level or low-level wake-up interrupt.
3. The module can support up to 8 PWM output channels, any GPIO can be configured for PWM function.
4. The PIN11 (RESET) pin is active low, and the internal 10K pull-up. General applications need to be suspended.If the RESET pin is used, must consult Pairlink for recommendations.
5. PIN18 (P3_1 / UART_RX), PIN19 (P3_0 /UART_TX) is configured as the module's UART interface by default,Refer to the SECTION A with 3V3_MCU communication.
6. J1 is development and debugging interfaces, that need to be reserved if the PCB space is sufficient

4.3.Appearance and Dimensions

Figure 2 shows the size of the module. The components and prominent structure are not allowed put in this size range(17.8mm*12.0mm*1.9mm).

The following land pattern size is recommended for user board design. However, user can modify it according PCB soldering conditions. Sufficient examination is necessary if use the modified land pattern.

Figure 2: Mechanical Information

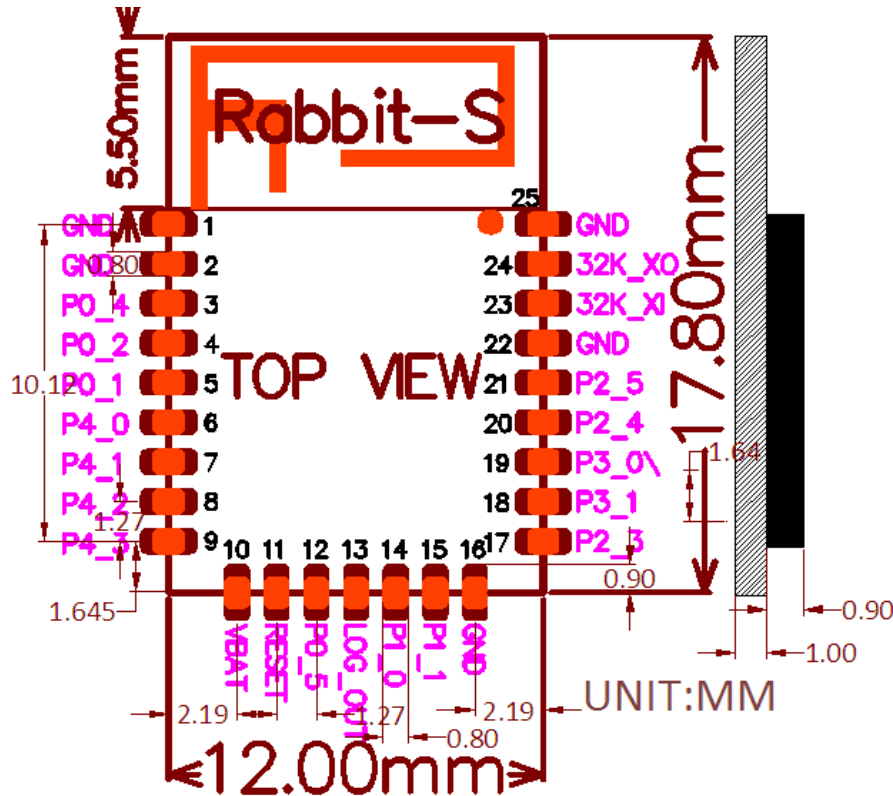

4.4.Module Layout Guideline

The layout on user PCB should be designed according to the following guideline.
 When the module is placed on the PCB, it must be ensured that the RF antenna area (2 times the width of the module) is hollow or suspended, and there must be no traces, vias or copper.

Figure 3: Module Placement

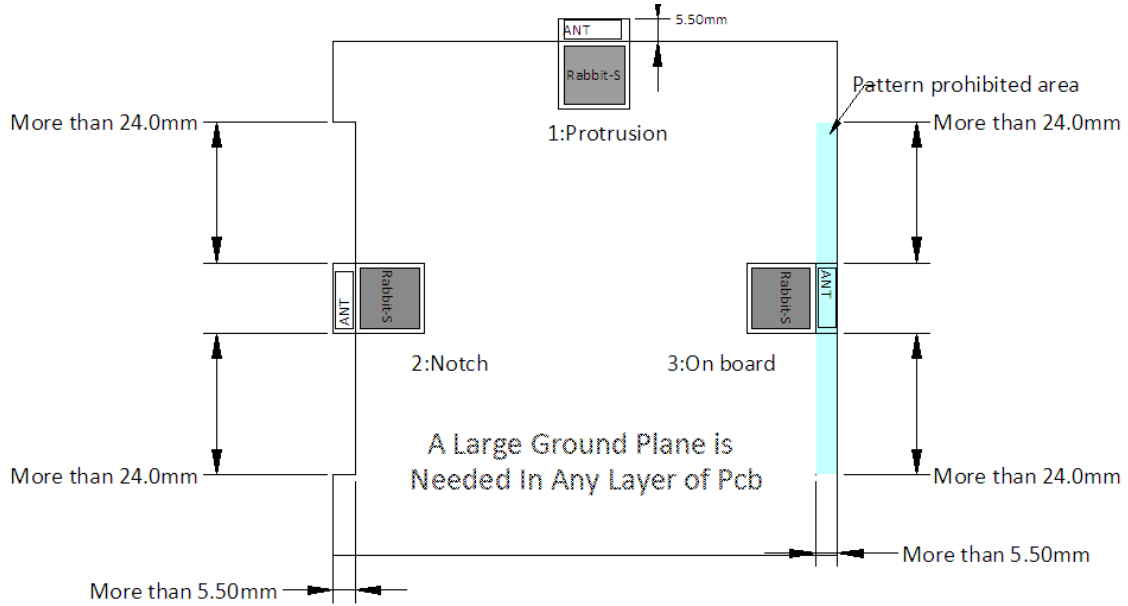

Suzhou Pairlink Network Technology Ltd.

5.Packing Information

5.1.Rolling Information

FL.13.120.00075 佩林Rabbit_S 载带图20210701.dwg.png

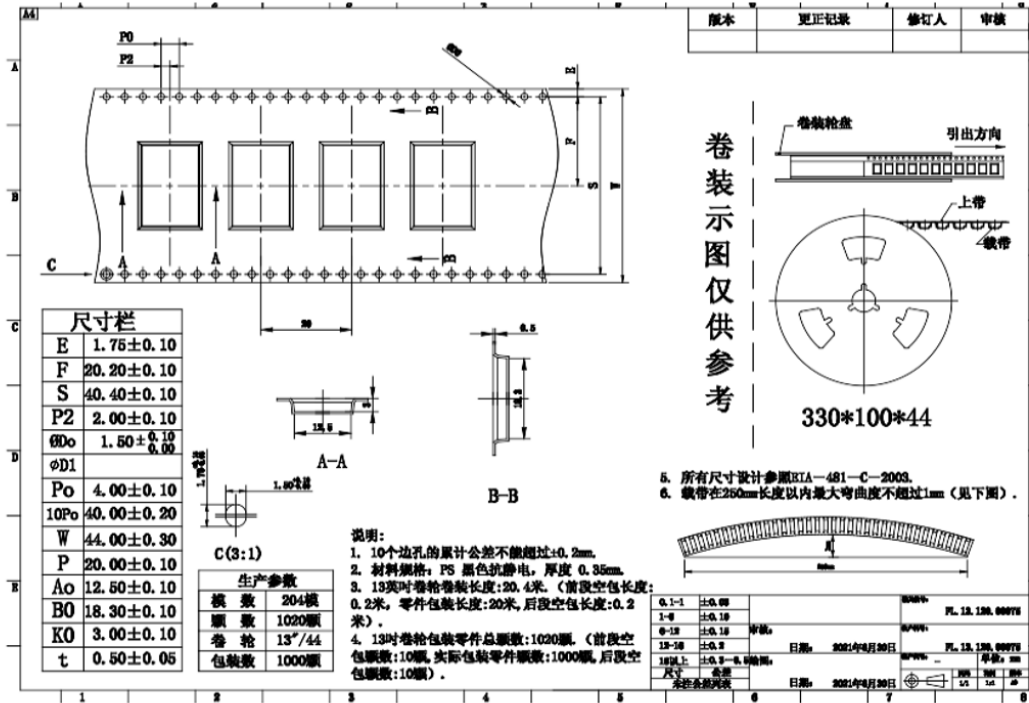

Product name	MOQ	Packing method	Single package quantity
Rabbit-S	1000PCS	Tape and Reel	1000PCS

6.Welding Declaration

The Rabbit-S module only supports one reflow soldering. Our company is not responsible for the module failure caused by multiple reflow soldering.

Figure 4: Reflow Soldering Temperature

Profile Feature	曲线特征	Sn-Pb Assembly	Pb-Free Assembly
Solder Paste	锡膏	Sn63/Pb37	Sn96.5/Ag3/Cu0.5
Preheat Temperature min (T _{smin})	最小预热温度	100°C	150°C
Preheat temperature max (T _{smax})	最大预热温度	150°C	200°C
Preheat Time (T _{smin} to T _{smax})(t _s)	预热时间	60-120 sec	60-120 sec
Average ramp-up rate(T _{smax} to T _p)	平均上升速率	3°C/second max	3°C/second max
Liquidous Temperature (T _L)	液相温度	183°C	217°C
Time (t _L) Maintained Above (T _L)	液相线以上的时间	60-90 sec	30-90 sec
Peak temperature (T _p)	峰值温度	220-235°C	230-250°C
Average ramp-down rate (T _p to T _{smax})	平均下降速率	6°C/second max	6°C/second max
Time 25°C to peak temperature	25°C到峰值温度的时间	6 minutes max	8 minutes max

Package Thickness	Volume < 350 mm ³	Volume 350 – 2000 mm ³	Volume > 2000 mm ³
< 1.6 mm	260 +0 /-5°C	260 +0/-5°C	260 +0 /-5°C
1.6 – 2.5 mm	260 +0 /-5°C	250 +0/-5°C	245 +0/-5°C
≥ 2.5 mm	250 +0 /-5°C	245 +0/-5°C	245 +0/-5°C

Figure 5: Reflow Soldering Curve

