

BM-8761BTV Bluetooth 5.0 Dual mode module

Description

The BM-8761BTV is dual-mode (BR/EDR + Low Energy) UART Interface and using Realtek RTL8761BTV chip complies with Bluetooth 5.0. It combines a BT Protocol Stack for LM, LL, L2CAP, GATT, RFCOMM, SPP and LE.

The BM-8761BTV is compatible with previous versions, including v2.1 + LE. For BR/EDR, it allows multiple active links in either slave mode or master mode. For Low Energy, it supports multiple states and allows multiple active links in slave mode. A BR/EDR link and an LE link can be active at the same time.

Features

- 16x10x1.85mm 18-pin
- Bluetooth 5 specification compliant
- Single end RF radio output with high performance of BR transmitter power and 2M EDR receiver sensitivity
- Supports Bluetooth classic (BR/EDR)
- Supports Bluetooth Low Energy (BLE)
- Complies with HS-UART with configurable baud rate for Bluetooth
- Supports Secure Simple Pairing
- Integrated MCU to execute Bluetooth protocol stack
- Supports Low Power Mode (Sniff mode)
- Supports multiple Low Energy states:
- Enhance BT/Wi-Fi Coexistence Control

to improve transmission quality in different profiles

- Fast AGC control to improve receiving dynamic range
- Supports Power Control

Application

- Internet of Things (IoT)
- Home automation
- Smart Home
- Home Entertainment

Revision History

Version	Date	Change Description
1.0	12/03/2019	Initial release
1.1	12/24/2019	Add Factory options

Note : All electrical and mechanical specifications may be changed by CC&C Technologies, Inc. without notice.

Factory options

- RF output by PCB Antenna(RF type-1), DFN Pads(RF type-2)

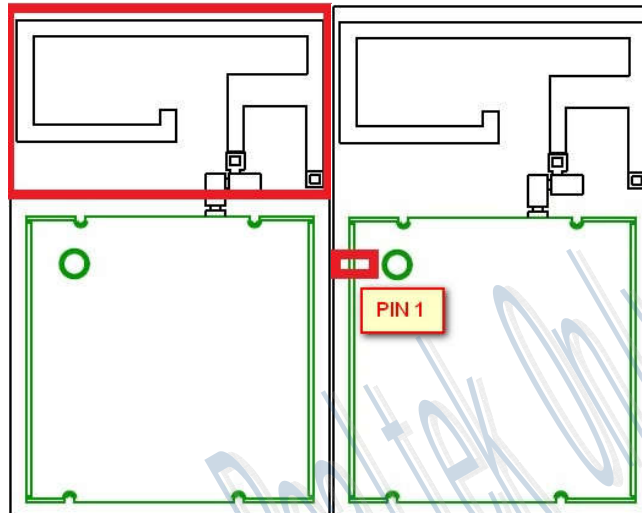

Block Diagram

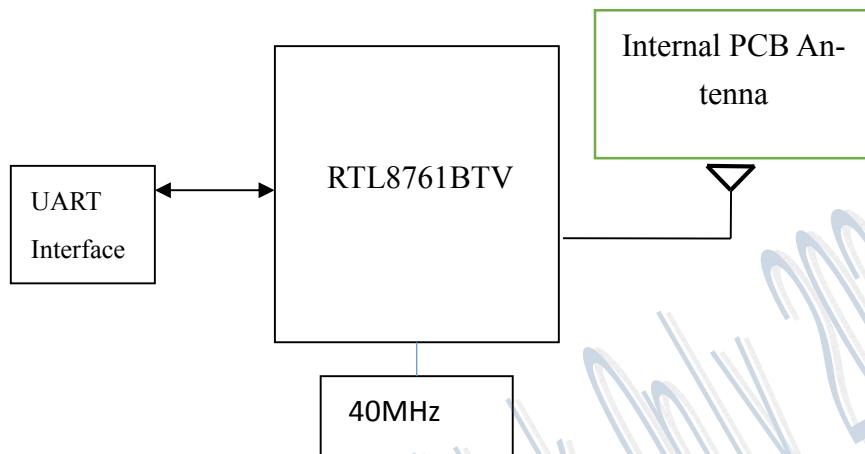

Pin Assignment (Top view)



Pin Definition

Pin	Pin Name	Pad Type	Description
1	RF_OUT	RF	RF output external Antenna
2	GND	Ground	
3	BT_STE	I	Internal pull low for normal operation
4	WLAN_ACT	PI	Internal pull low for normal operation
5	UART_CTS_IN	I	UART Interface CTS input for HW flow control
6	P_LED[0]	O	LED Pin (Active Low)
7	UART_OUT	O	UART Interface Output
8	PCM_CLOCK	I/O	Peripheral Interface
9	PCM_SYNC	I/O	Peripheral Interface
10	PCM_IN	I/O	Peripheral Interface
11	PCM_OUT	I/O	Peripheral Interface
12	VD33	PI	3.3V Supply Voltage
13	GND	Ground	
14	UART_IN	I	UART Interface Input
15	UART_RTS_OUT	O	UART Interface RTS output for HW flow control
16	CLK_REQ	O	Clock request signal
17	BT_WAKE_HOST	O	BT wakeup host signal
18	EN_CHIP	I/O	BT function disable

I: Input
 O: Output
 PI: Power input
 RF:RF OUT

SPECIFICATION

Product Name	Bluetooth 5.0 dual-mode Module
Model Number	E57
Operating Frequency	2402~2480 MHz
Tx power	-6~+4dBm(class 2)
Receiver sensitivity	< -70dBm

Power Voltage Range

Symbol	Description	Min.	Typ.	Max.	Units
VD33	3.3V Supply Voltage	3.0	3.3	3.6	V
	Operating Temperature	0	25	50	°C

Digital logic characteristics (3.3V I/O operation)

symbol	parameter	Min.	Typ.	Max.	Unit
Vih	High level input voltage	2.0	3.3	3.6	V
Vil	Low level input voltage	-	0	0.9	V
Voh	High level output voltage	2.97	-	3.3	V
Vol	Low level output voltage	0	-	0.33	V

Module RF Feed point

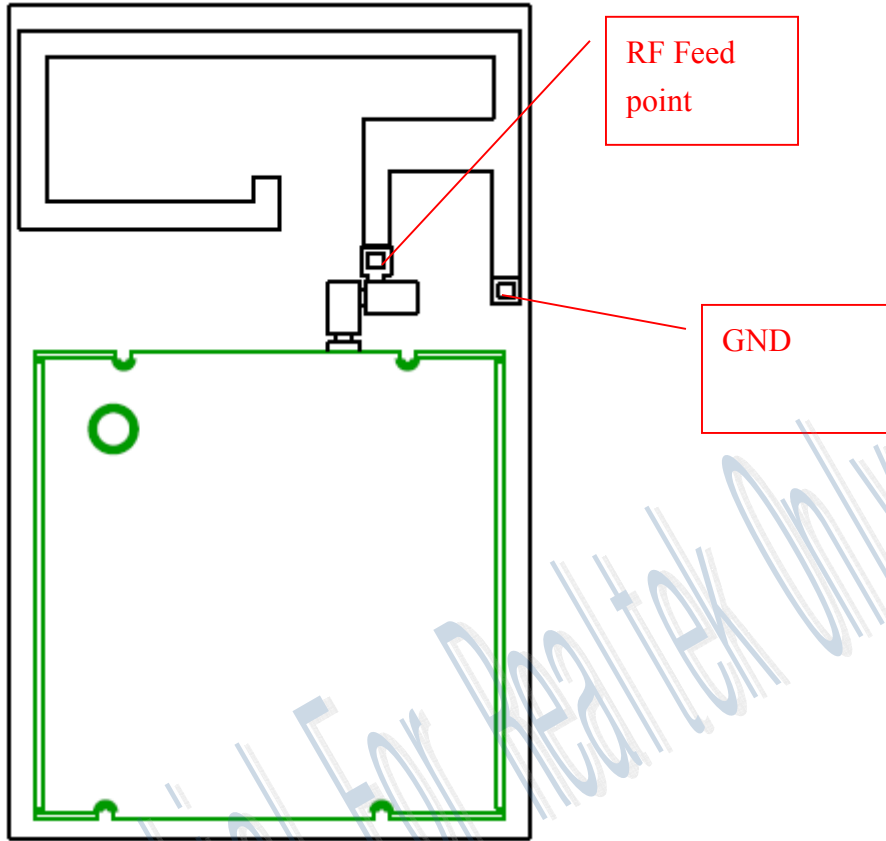

Placement Guideline RF type-1

It is recommended that BM-8761BTV be placed on the corner of the main board or near the edge as shown below.

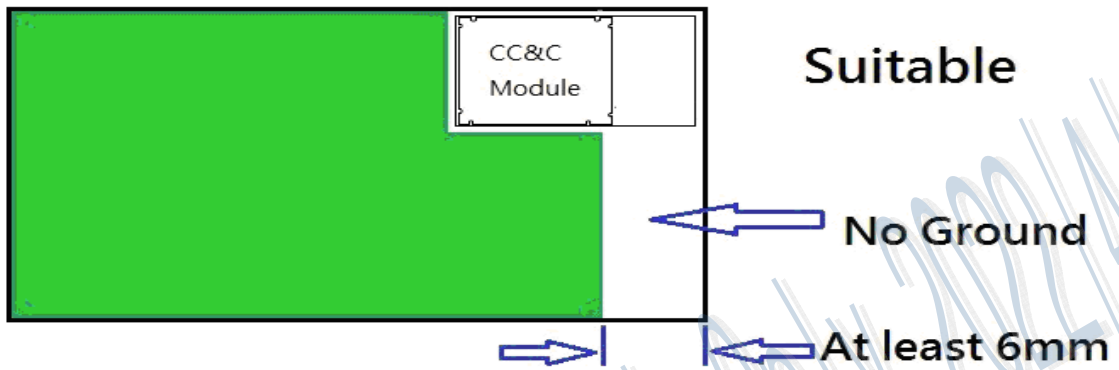

On the corner

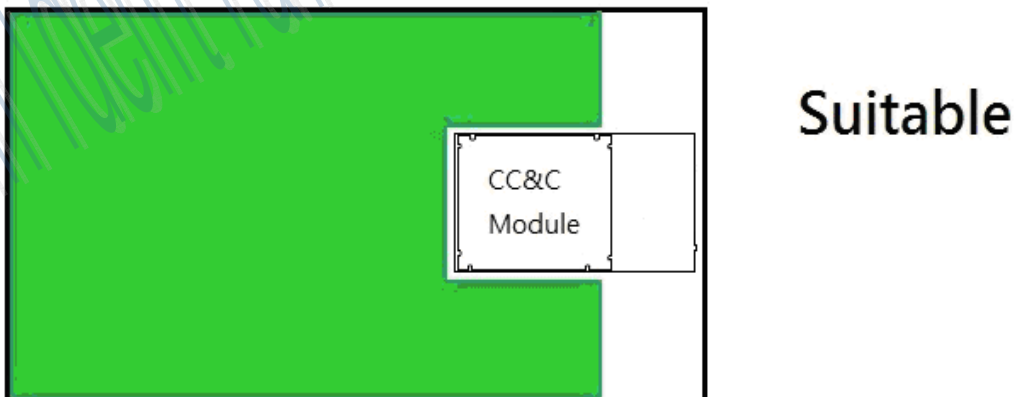

Near the edge

However, placing BM-8761BTV inside the main board affects the RF performance and may reduce the RF range significantly.

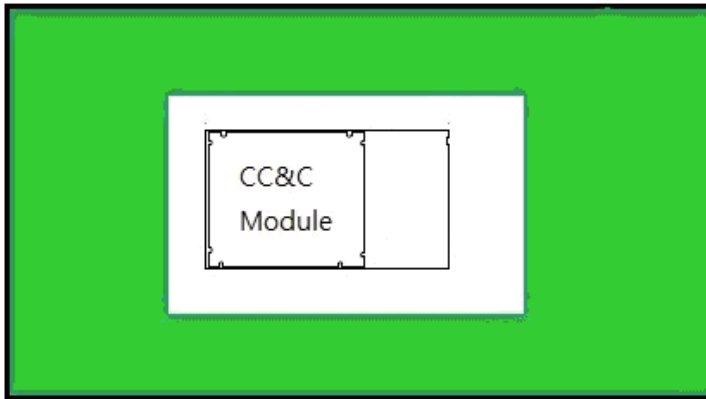

Unsuitable

RF type-2

- In order to get a better RF performance, please don't put any trace or copper plane under Black frame of the module.

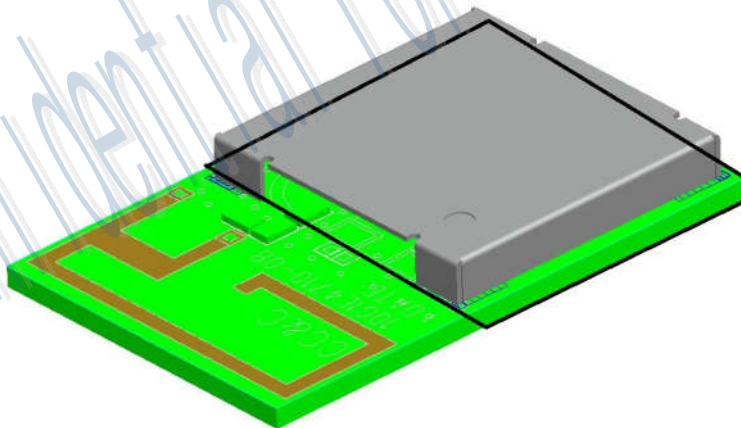

● **RF out**

Please have the impedance of feed lines to be 50 ohms from RF output pin to Antenna.

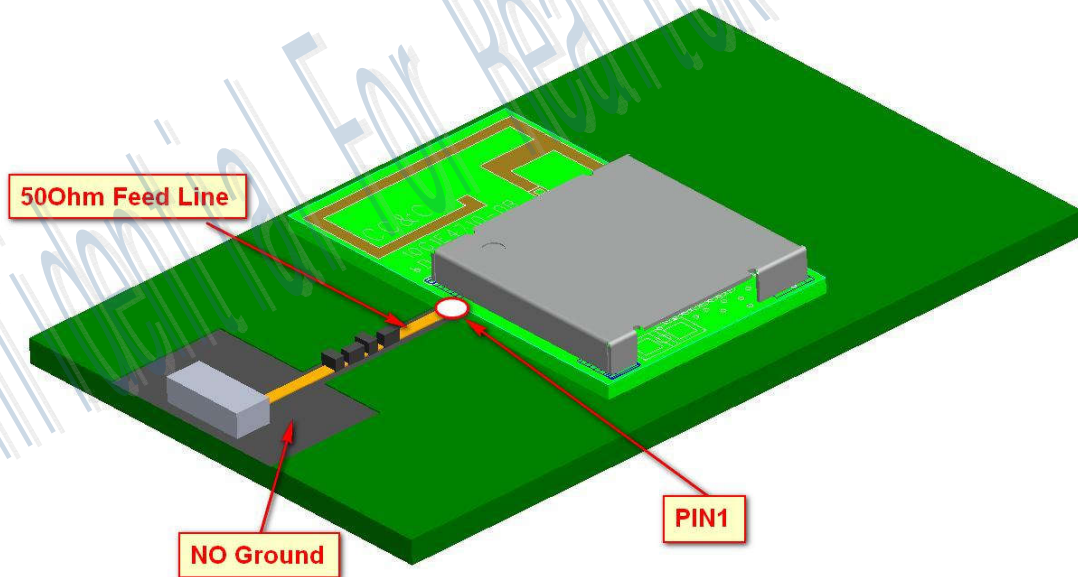
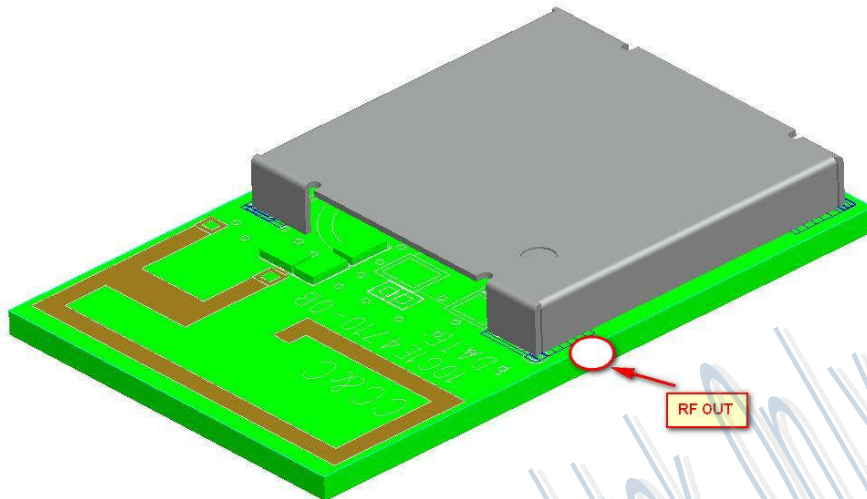

50 Ohm Feed line:

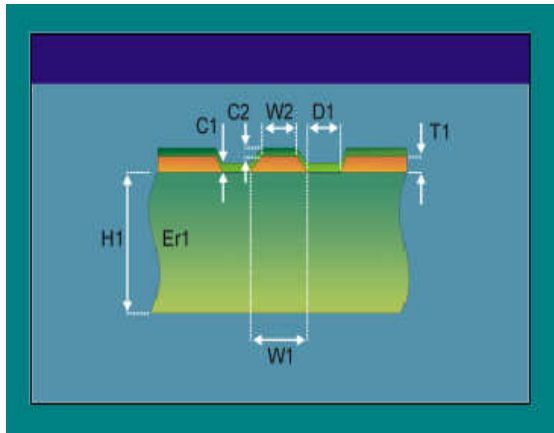

- H1: 20 ~ 60 mil
- Er1: 4.2
- W1: 20 mil
- W2: 20 mil
- D1: 5 mil
- C1: 0.7 mil
- C2: 0.7 mil
- T1: 1.4 mil (1 oz)

Impedance: 51 ~ 53 Ohm

Reference – Temperature Reflow Chart

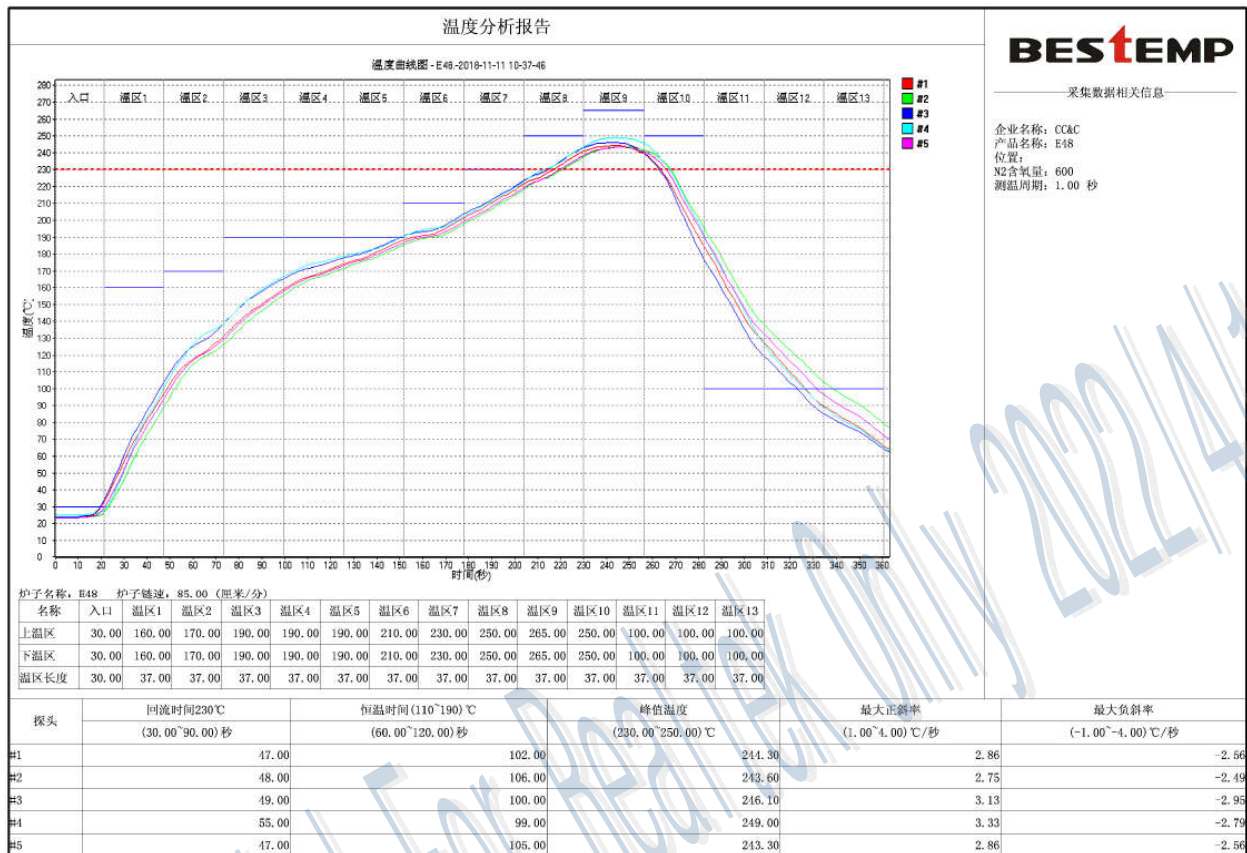

Reflow Notice:

1. If the system PCBA is double side design, please reflow the side without this module first.
2. Don't let the solder machine temperature over 250 °C or follow solder paste vendors's recommened temperature.
3. The Ramp-up temperature speed is 1-4 °C per second, the Ramp-down temperature speed is 1-4 °C per second.
4. This temperature reflow chart is for reference only, it depends on the manufacturing machine's characters requirement.

This module is surface mount device; please refer below conditions for drying before solder reflow processes. (extracted from IPC/JEDEC J-STD-033B.1)

Bake @ 125 °C		Bake @ 90 °C		Bake @ 40 °C	
Exceeding floor Life By > 72h	Exceeding floor Life By ≤ 72h	Exceeding floor Life By > 72h	Exceeding floor Life By ≤ 72h	Exceeding floor Life By > 72h	Exceeding floor Life By ≤ 72h
9 hours	7 hours	33 hours	23 hours	13 days	9 days